

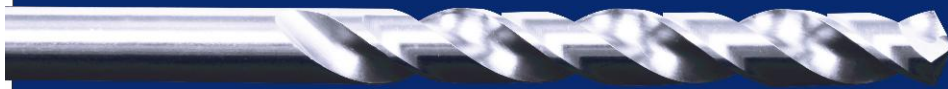

**MIRANDA TOOLS**  
Premium quality cutting tools



ASHOK  
PIRAMAL  
GROUP



**MIRANDA Super Drills**

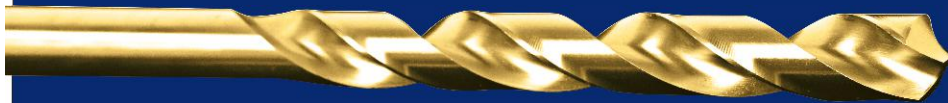

**MIRANDA Gold Drills**



[www.mirandatools.net](http://www.mirandatools.net)





# MIRANDA TOOLS

## MIRANDA Super Drills (Precision drilling on hard material)

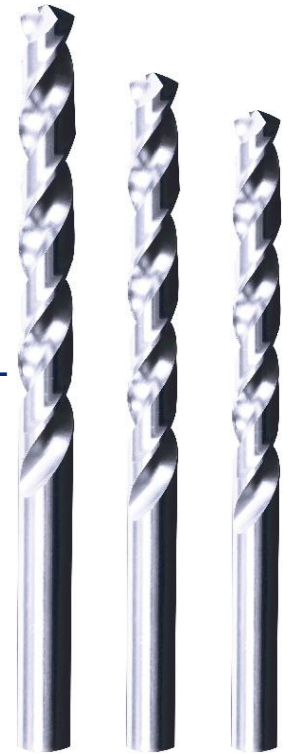
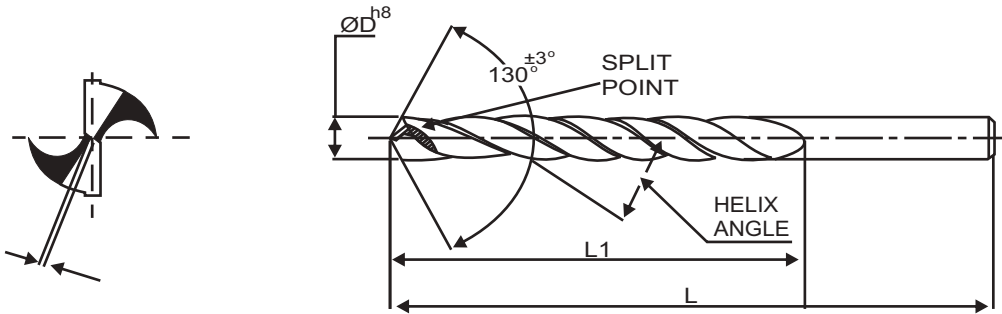

### APPLICATION :

- Drilling alloy steel up to 28-35 HRc.
- Suitable for drilling all types of stainless steel materials.
- Suitable for forged steel components.
- All Titanium alloys, Hastelloy, Inconel and Heat Resistant steels

### SIZE RANGE : SUPER JOBBER DRILL

- Metric size : 1.00 mm to 16.0 mm
- Inch size : 3/64" to 5/8"

### ADVANTAGES :

- **High helix flute** and reinforced web gives maximum rigidity.
- Improved cutting action and faster chip evacuation.
- Self centering drill with special web thinning that reduces thrust.
- Trouble free drilling for high alloy steel material.
- Reduced contact area that results into less heat generation.
- Good for drilling on curved surface.
- Up to 100% higher productivity as compared to standard drill on hard metal drilling.

130° self-centering split point that requires less torque and thrust in machine drilling and thus reduce axial force and increases tool life. This point helps break up chips in deep hole drilling and is an excellent choice when used on CNC equipment.

130° Split Point

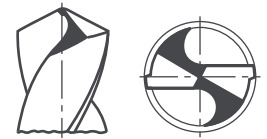

### SPEED AND FEED FOR DRILLING

Work Material	Steels containing a high proportion (>10%) of nickelchrome and nickle		Corrosion and heat resisting alloys containing a high proportion of carbon, chrome, and molybdenum		Titanium Alloy	
	cutting speed 10 m / min.		cutting speed 6.3 m / min.		cutting speed 4 m / min.	
Cutting Condition	Rev. per min	Feed mm / rev.	Rev. per min	Feed mm / rev.	Rev. per min	Feed mm / rev.
2.0	1600	0.020	1000	0.020	630	0.020
2.5	1250	0.020	800	0.020	500	0.020
3.15	1000	0.030	630	0.030	400	0.030
4.0	800	0.040	500	0.040	315	0.040
5.0	630	0.050	400	0.040	250	0.040
6.3	500	0.060	315	0.040	200	0.040
8.0	400	0.080	250	0.060	160	0.060
10.0	315	0.100	200	0.080	125	0.080
12.50	250	0.100	160	0.080	100	0.080



# MIRANDA TOOLS

## MIRANDA Gold Drills (Precision & Long Life Drilling)

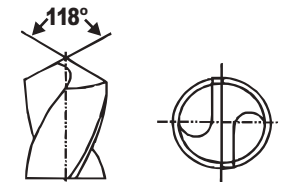
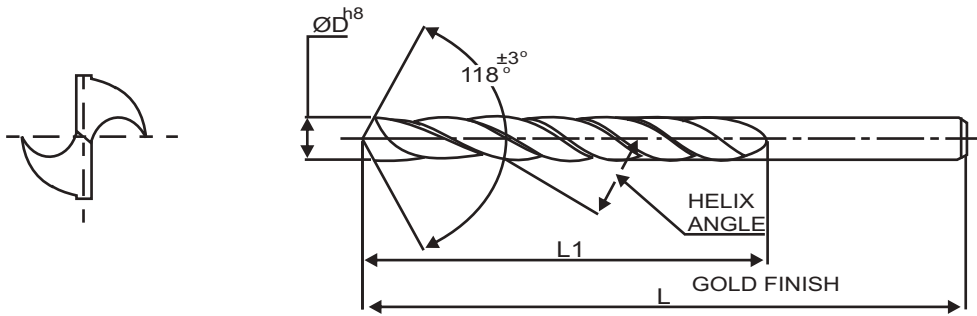

### SIZE RANGE : GOLD JOBBER DRILL

- Metric size : 1.0 mm to 20.0 mm
- Inch size : 3/64" to 25/32"

### SIZE RANGE : GOLD LONG DRILL

- Metric size : 1.00 mm to 16.0 mm
- Inch size : 3/64" to 5/8"

### SIZE RANGE : GOLD STUB DRILL

- Metric size : 1.5 mm to 16.0 mm
- Inch size : 5/64" to 5/8"

### APPLICATION :

- Suitable for non ferrous metals.
- Suitable for aluminium alloy & Cast steel material.
- Suitable for material up to 25HRc.
- Suitable for general application

### ADVANTAGES :

- Premium-grade industrial steel & super hard performance coating for longer life, heat resistance & precision drilling.
- Unique flute design for superior material removal.
- Special heat treatment provides additional strength.
- Improve hole finish due to better lubrication properties.
- Improve 30% productivity as compared to standard drill

### SPECIALLY DESIGNED :

- Specially designed & treated for precision drilling in general purpose steel for longer life & heat resistance.
- Performs well in broad range of material in the iron & steel categories.

### SPEED AND FEED FOR DRILLING

Work Material Cutting Condition Dia. (mm)	Steels		Cast iron		Alloy Steel		Aluminium		Copper		Stainless Steel		Plastic		Magnesium Alloy		Brass	
	rpm	mm/rev	rpm	mm/rev	rpm	mm/rev	rpm	mm/rev	rpm	mm/rev	rpm	mm/rev	rpm	mm/rev	rpm	mm/rev	rpm	mm/rev
2	3550	0.03	3550	0.03	1800	0.02	10000	0.03	2800	0.03	1800	0.03	8000	0.03	14000	0.03	5000	0.04
3	2240	0.06	2240	0.06	1120	0.03	6300	0.06	1800	0.06	1120	0.06	5000	0.06	9000	0.06	3150	0.08
5	1400	0.11	1400	0.11	710	0.05	4000	0.11	1120	0.11	710	0.11	3150	0.11	5600	0.11	2000	0.14
8	900	0.16	900	0.16	450	0.08	2500	0.16	710	0.16	450	0.16	2000	0.16	3550	0.16	1250	0.20
12	560	0.22	560	0.22	280	0.11	1600	0.22	450	0.22	280	0.22	1250	0.22	2240	0.22	800	0.28
16	450	0.25	450	0.25	224	0.13	1250	0.25	355	0.25	224	0.25	1000	0.25	1800	0.25	630	0.33
20	355	0.30	355	0.30	180	0.15	1000	0.30	280	0.30	180	0.30	800	0.30	1400	0.30	500	0.38



## MIRANDA TOOLS

(An Ashok Piramal Group company)

**WORKS AND HEAD OFFICE :** 903 / 904, GIDC Industrial Estate, Ankleshwar - 393 002. Gujarat.

Tele : (02646) 221519, 252368, 239707 Fax : (02646) 251326

E-mail : [marketing@mirandatools.net](mailto:marketing@mirandatools.net) website : [www.mirandatools.in](http://www.mirandatools.in)

Customer Care No. (02646) - 227162

### BRANCH OFFICES

#### MUMBAI

Dharma Pratap Co-operative Hsg. Society,  
Shop No. 3, Ashok Road, Kandivali (E) Mumbai - 400 101.  
Cell No. : 09323823470/71 Tele / Fax : 022-28855153  
[mumbai@mirandatools.net](mailto:mumbai@mirandatools.net)

#### PUNE

Salamatrai Mini Complex, Opp. Roplas India Ltd.  
Pimpri, Pune - 411018  
Cell No. : 09371223472/75 Tele/fax : 020-27423411  
[Pune@mirandatools.net](mailto:Pune@mirandatools.net)

#### AHMEDABAD

Star Mansion, 1st Floor, Opp. Electricity House  
Relief Road, Ahmedabad - 380 001.  
Cell No. : 9328223476/77 Tele / Fax : 079-25507421  
[ahmedabad@mirandatools.net](mailto:ahmedabad@mirandatools.net)

#### INDORE

201, Harsh Paradise, 95A-47 Scheme,  
Sapna Sangeeta Road, Indore - 452 001.  
Cell : 09302423479 Tele / Fax : 0731-2472168  
[indore@mirandatools.net](mailto:indore@mirandatools.net)

#### NEW DELHI

1/22-B, Asaf Ali Road, New Delhi - 110 002  
Cell No. : 9350885015 / 9313023481  
Tele / Fax : 011-23236319  
[delhi@mirandatools.net](mailto:delhi@mirandatools.net)

#### FARIDABAD

2a/46A, N.I.T. Faridabad, Near Hardware Chowk,  
Faridabad - 121 001 Cell : 09313993118 / 9350623483  
Tele / Fax : 0129-2423126, [faridabad@mirandatools.net](mailto:faridabad@mirandatools.net)

#### LUDHIANA

1169, GILL ROAD, LUDHIANA - 141 003  
Cell No. : 09356706157 / 9317823485  
Tele / Fax : 0161-2532028 [ludhiana@mirandatools.net](mailto:ludhiana@mirandatools.net)

#### KOLKATA

5-B, Narendrachandra, Dutta Sarani, Kolkata - 700 001.  
Cell No. : 09331701000 / 9339703486  
Tele / Fax : 033 22304115, [kolkata@mirandatools.net](mailto:kolkata@mirandatools.net)

#### CHENNAI

18, Perianna Maistry Street, 2nd Floor Chennai - 600 001.  
Cell No. : 09381223492 / 9381223490  
Tele / Fax : 044-25383351 [chennai@mirandatools.net](mailto:chennai@mirandatools.net)

#### BANGALORE

No.24 lind Floor, Kota Complex, J. C. Road,  
Bangalore - 560002 Cell No. : 09343143494 / 9341323491  
Tele / Fax : 080-22234045 [bangalore@mirandatools.net](mailto:bangalore@mirandatools.net)

#### SECUNDERABAD

8-1-11/7, 2nd Floor, Market Street, Secunderabad - 500 003  
Cell No. : 09346210922 / 9393023494 Tele : 040-27713910  
[secunderabad@mirandatools.net](mailto:secunderabad@mirandatools.net)

**Authorised Dealer**

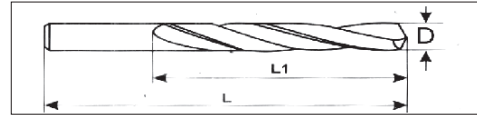

**HSS JOBBER DRILLS - IS : 5101 - 1991**
**DIN : 338 & BS-328 Part-1**

DIA IN MM (D)	FLUTE LENGTH MM (L1)	OVERALL LENGTH MM (L)	PCK QTY NOS.
1.00	12	34	10
1.05	12	34	10
1.10	14	36	10
1.15	14	36	10
1.20	16	38	10
1.25	16	38	10
1.30	16	38	10
1.35	18	40	10
1.40	18	40	10
1.45	18	40	10
1.50	18	40	10
1.55	20	43	10
1.60 (1/16")	20	43	10
1.65	20	43	10
1.70	20	43	10
1.75	22	46	10
1.80	22	46	10
1.85	22	46	10
1.90	22	46	10
1.95	24	49	10
2.00 (5/64")	24	49	10
2.05	24	49	10
2.10	24	49	10
2.15	27	53	10
2.20	27	53	10
2.25	27	53	10
2.30	27	53	10
2.30	27	53	10
2.40	30	57	10
2.45	30	57	10
2.50	30	57	10
2.55	30	57	10
2.60	30	57	10
2.65	30	57	10
2.70	33	61	10
2.78 (7/64")	33	61	10
2.80	33	61	10
2.85	33	61	10
2.90	33	61	10
3.00	33	61	10
3.10	36	65	10

DIA IN MM (D)	FLUTE LENGTH MM (L1)	OVERALL LENGTH MM (L)	PCK QTY NOS.
3.15	36	65	10
3.20 (1/8")	36	65	10
3.25	36	65	10
3.30	36	65	10
3.40	39	70	10
3.50	39	70	10
3.60 (9/64")	39	70	10
3.65	39	70	10
3.70	39	70	10
3.75	39	70	10
3.80	43	75	10
3.90	43	75	10
3.95	43	75	10
4.00 (5/32")	43	75	10
4.05	43	75	10
4.10	43	75	10
4.15	43	75	10
4.20	43	75	10
4.25	43	75	10
4.30	47	80	10
4.37 (11/64")	47	80	10
4.40	47	80	10
4.50	47	80	10
4.55	47	80	10
4.60	47	80	10
4.70	47	80	10
4.75 (3/16")	52	86	10
4.80	52	86	10
4.85	52	86	10
4.90	52	86	10
4.95	52	86	10
5.00	52	86	10
5.10	52	86	10
5.20 (13/64")	52	86	10
5.25	52	86	10
5.30	52	86	10
5.40	57	93	10
5.50	57	93	10
5.60 (7/32")	57	93	10
5.70	57	93	10
5.75	57	93	10

**HSS JOBBER DRILLS - IS : 5101 - 1991  
DIN : 338 & BS-328 Part-1**

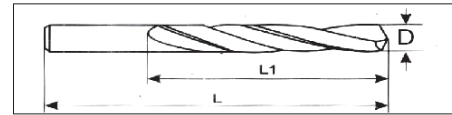

DIA IN MM (D)	FLUTE LENGTH MM (L1)	OVERALL LENGTH MM (L)	PCK QTY NOS.
5.80	57	93	10
5.90	57	93	10
6.00 (15/64")	57	93	10
6.10	63	101	10
6.20	63	101	10
6.25	63	101	10
6.30	63	101	10
6.40 (1/4")	63	101	10
6.50	63	101	10
6.60	63	101	10
6.70	63	101	10
6.75 (17/64")	69	109	10
6.80	69	109	10
6.90	69	109	10
7.00	69	109	10
7.10	69	109	10
7.20 (9/32")	69	109	10
7.25	69	109	10
7.30	69	109	10
7.40	69	109	10
7.50	69	109	10
7.60 (19/64")	75	117	10
7.70	75	117	10
7.75	75	117	10
7.80	75	117	10
7.90	75	117	10
8.00 (5/16")	75	117	10
8.10	75	117	10
8.20	75	117	10
8.30	75	117	10
8.40 (21/64")	75	117	10
8.50	75	117	10
8.60	81	125	10
8.65	81	125	10
8.70	81	125	10
8.75 (11/32")	81	125	10
8.80	81	125	10
8.90	81	125	10
9.00	81	125	10
9.10 (23/64")	81	125	10
9.20	81	125	10
9.25	81	125	10

DIA IN MM (D)	FLUTE LENGTH MM (L1)	OVERALL LENGTH MM (L)	PCK QTY NOS.
9.30	81	125	10
9.40	81	125	10
9.50	81	125	10
9.60 (3/8")	87	133	10
9.70	87	133	10
9.75	87	133	10
9.80	87	133	10
9.90	87	133	10
10.00 (25/64")	87	133	10
10.10	87	133	10
10.20	87	133	10
10.25 (13/32")	87	133	10
10.30	87	133	10
10.40	87	133	10
10.50	87	133	10
10.60	87	133	10
10.70 (27/64")	94	142	10
10.75	94	142	10
10.80	94	142	10
10.90	94	142	10
11.00	94	142	10
11.10 (7/16")	94	142	10
11.20	94	142	10
11.25	94	142	10
11.30	94	142	10
11.40	94	142	10
11.50 (29/64")	94	142	10
11.60	94	142	10
11.70	94	142	10
11.75	94	142	10
11.80	94	142	10
11.90 (15/32")	101	151	10
12.00	101	151	10
12.10	101	151	10
12.20	101	151	10
12.25	101	151	10
12.30 (31/64")	101	151	10
12.40	101	151	10
12.50	101	151	10
12.60	101	151	10
12.70 (1/2")	101	151	10
12.75	101	151	10

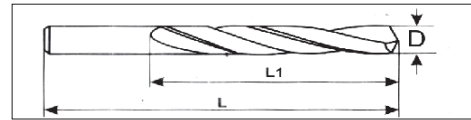
**HSS JOBBER DRILLS - IS : 5101 - 1991**
**DIN : 338 & BS-328 Part-1**

**HSS JOBBER DRILLS - LETTER GAUGE**

DIA IN MM (D)	FLUTE LENGTH MM (L1)	OVERALL LENGTH MM (L)	PCK QTY NOS.
12.80	101	151	10
12.90	101	151	10
13.00	101	151	10
13.10	101	151	01
13.20	101	151	01
13.25	108	160	01
13.30	108	160	01
13.40	108	160	01
13.50	108	160	01
13.60	108	160	01
13.70	108	160	01
13.75	108	160	01
13.80	108	160	01
13.90	108	160	01
14.00	108	160	01
14.20	114	169	01
14.30	114	169	01
14.50	114	169	01
14.75	114	169	01
15.00	114	169	01
15.15	120	178	01
15.25	120	178	01
15.30	120	178	01
15.50	120	178	01
15.75	120	178	01
16.00	120	178	01
16.50	125	184	01
16.70	125	184	01
17.00	125	184	01
17.50	130	191	01
18.00	130	191	01
18.50	135	198	01
19.00	135	198	01
19.50	140	205	01
20.00	140	205	01

Metric Sizes As Per BS 328 Part 1				PCK QTY NOS.
Letter Gauge	Drill Size	Flute Length	Overall Length	
	dmm	L1mm	Lmm	
LG A	5.94	57	93	10
LG B	6.04	63	101	10
LG C	6.15	63	101	10
LG D	6.25	63	101	10
LG E	6.35	63	101	10
LG F	6.35	63	101	10
LG G	6.63	63	101	10
LG H	6.75	69	109	10
LG I	6.90	69	109	10
LG J	7.03	69	109	10
LG K	7.14	69	109	10
LG L	7.37	69	109	10
LG M	7.49	69	109	10
LG N	7.67	75	117	10
LG O	8.03	75	117	10
LG P	8.20	75	117	10
LG Q	8.43	75	117	10
LGR	8.61	81	125	10
LGS	8.84	81	125	10
LG T	9.09	81	125	10
LG U	9.34	81	125	10
LG V	9.58	87	133	10
LG W	9.80	87	133	10
LG X	10.08	87	133	10
LG Y	10.26	87	133	10
LG Z	10.49	87	133	10

Note : All items required minimum order value of Rs.20,000/-.

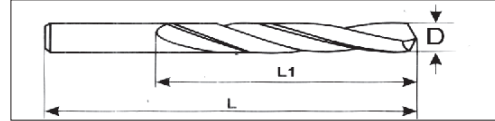
## HSS JOBBER DRILLS - IS : 5101 - 1991 BS : 328 Part-1



Metric Sizes As Per BS 328 Part 1				PCK QTY NOS.
Wire Gauge	Drill Size	Flute Length	Overall Length	
No.	Dmm	L1mm	Lmm	
WG 60	1.02	12	34	10
WG 59	1.04	12	34	10
WG 58	1.07	14	36	10
WG 57	1.09	14	36	10
WG 56	1.18	14	36	10
WG 55	1.32	16	38	10
WG 54	1.40	18	40	10
WG 53	1.51	20	43	10
WG 52	1.61	20	43	10
WG 51	1.70	20	43	10
WG 50	1.78	22	46	10
WG 49	1.85	22	46	10
WG 48	1.93	24	49	10
WG 47	1.99	24	49	10
WG 46	2.06	24	49	10
WG 45	2.08	24	49	10
WG 44	2.18	27	53	10
WG 43	2.26	27	53	10
WG 42	2.37	30	57	10
WG 41	2.44	30	57	10
WG 40	2.49	30	57	10
WG 39	2.53	30	57	10
WG 38	2.58	30	57	10
WG 37	2.64	33	61	10
WG 36	2.71	33	61	10
WG 35	2.79	33	61	10
WG 34	2.82	33	61	10
WG 33	2.87	33	61	10
WG 32	2.95	33	61	10
WG 31	3.05	36	65	10

Metric Sizes As Per BS 328 Part 1				PCK QTY NOS.
Wire Gauge	Drill Size	Flute Length	Overall Length	
No.	Dmm	L1mm	Lmm	
WG 30	3.26	36	65	10
WG 29	3.45	39	70	10
WG 28	3.57	39	70	10
WG 27	3.66	39	70	10
WG 26	3.73	39	70	10
WG 25	3.80	43	75	10
WG 24	3.86	43	75	10
WG 23	3.91	43	75	10
WG 22	3.99	43	75	10
WG 21	4.04	43	75	10
WG 20	4.09	43	75	10
WG 19	4.22	43	75	10
WG 18	4.30	47	80	10
WG 17	4.39	47	80	10
WG 16	4.50	47	80	10
WG 15	4.57	47	80	10
WG 14	4.62	47	80	10
WG 13	4.70	52	86	10
WG 12	4.80	52	86	10
WG 11	4.85	52	86	10
WG 10	4.92	52	86	10
WG 9	4.98	52	86	10
WG 8	5.06	52	86	10
WG 7	5.11	52	86	10
WG 6	5.18	52	86	10
WG 5	5.22	52	86	10
WG 4	5.31	57	93	10
WG 3	5.41	57	93	10
WG 2	5.61	57	93	10
WG 1	5.79	57	93	10